

We at ergoCentric, want to ensure the adjustment features of your chair are easily understood. We believe the proper use of these features is critical and will ensure you receive the full benefits of your ergonomic chair.

Call us if you have any questions and ask for a customer support representative.

ergoCentric®

ph: 1 866 GET ERGO | 905 696 6800

fx: 1 800 848 5190 | 905 696 0899

service@ergocentric.com

ergocentric.com



Printed in Canada.

Adjustability understood™

To get the most out of your chair, please take a minute to learn about its adjustment features.

Read this user guide

Bariatric Task

ergoCentric®
ergocentric.com

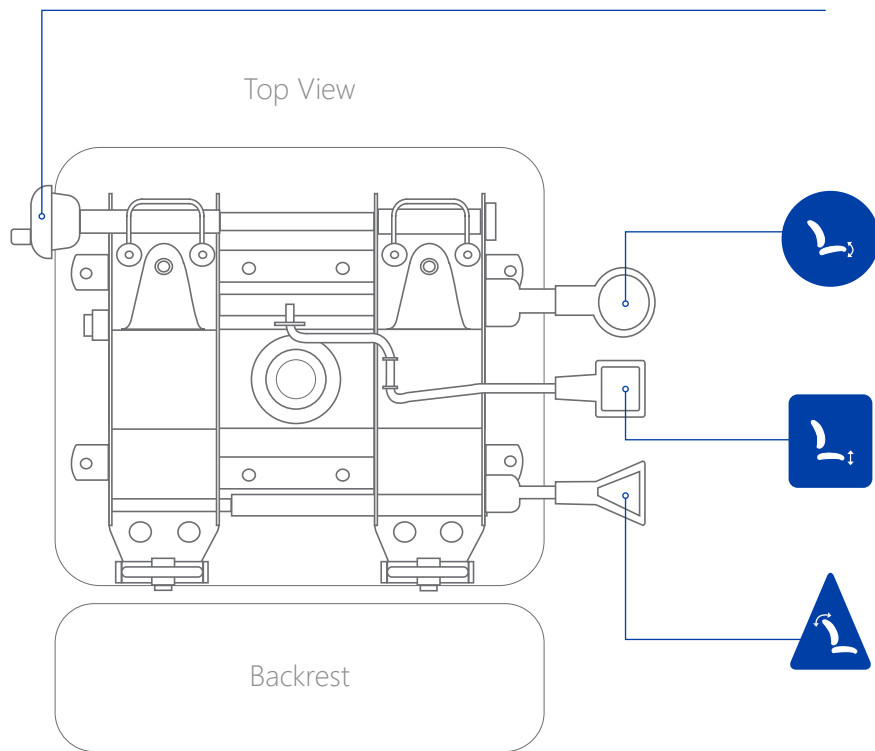

SPRING TENSION: To adjust the spring tension, turn the knob located under the front right corner of the seat. Turn the knob clockwise to increase the spring tension and counter-clockwise to decrease the spring tension.

SEAT ANGLE / FREE FLOAT: To adjust the seat angle, pull up on the **CIRCULAR** paddle and shift your weight forward or backward until the seat is at the desired angle. Push this paddle down to lock. To free float the chair, pull this paddle all the way up and leave it in the up position.

SEAT HEIGHT: To raise the seat, pull up on the **SQUARE** paddle while raising your weight off the chair. To lower the seat, pull up on the paddle while sitting. Release the paddle to lock.

BACK ANGLE: To adjust the back angle, pull up on the **TRIANGULAR** paddle and hold it in the up position. Lean backward or forward until the backrest is at the desired angle. Release the paddle to lock. When adjusted correctly the angle between your upper body and thighs should be greater than 90°.